



Wireless Motor controller

Instruction Manual

Models:

WMCseries: WMC12, WMC8

version 2.1 – SIL-3 emergency

ATTENTIONS

This instruction manual contains important information about the installation and use of the equipment. Please read and follow these instructions carefully. Always ensure that the power to the equipment is disconnected before opening the equipment or commencing any maintenance work.

1. Safety information

IMPORTANT INSTRUCTIONS!

All safety and operating instructions should be read before the equipment is installed or operated.

IMPORTANT SAFETY INFORMATIONS

The following general safety precautions have to be observed during all phases of operation, service, and repair of this equipment. Failure to comply with these precautions or with specific warning in this manual violates safety standards of design, manufacture, and intended use of this equipment.

Do not operate in an explosive atmosphere

Do not operate this equipment in the presence of flammable gases or fumes. Operation of any electrical instrument in such an environment constitutes a definite safety hazard.

Water, moisture, heat and humidity

Do not operate this equipment near water or in areas with wet floors, also not in high humidity atmosphere where condensation forms on the equipment. It should never be placed near or over heat register or other source of heated air and it should not be installed or operated without proper ventilation.

2. Functions and Control

Wireless Motor Controller has been designed to control from 4 to 12 electrically compatible motors in separately or simultaneously way via wireless remote or locally on WMCseries base unit.

Each device is equipped with unique wireless module working on 2.4 GHz with many features guarantees solid and stable wireless connection, error correction

All electrical components carry their own individual CE certification and comply with European Directives. The components are housed in robust steel 19" rack case with powder coating.

3. Operation

The Motor/hoists connected with the MCseries controller, can be activated individually or simultaneously using the GO switch located on the corresponding WMCseries controller base or remote station

3.1 How to start

- Connect the Main plug to the 230V AC power supply / on MCseries controller this is marked as AUX output.
- Connect Remote connector to the MCseries controller
- Connect Remote2/E-stop connector to the MCseries controller
- Select type of operation LOCAL / REMOTE by the KEY switch
- Check that the emergency STOP mushroom is not engaged
- Engage the gear lever corresponding to each motor, to the position required:
 - UP - Lever in upper position
 - STAY – Lever in middle position
 - DOWN - Lever in lower position
- Pushing the GO button will activate the motors to move simultaneously
- Releasing the GO button will cease the movement of the motors, simultaneously.
- When is device not used is highly recommended to turn it OFF by key switch or STOP mushroom

3.2 To Move a Single Motor:

- Set the UP/DOWN toggle switch for that motor to the desired direction. The associated LED should light Green for UP, or Red for DOWN.
- Press the GO button until the motor has moved the desired distance, then release.
- Until remote unit is not used please turn it off via STOP button
- Unit will automatically sleep if it's not used for more than 3 minutes – this state is signaled by blinking of GREEN LED on both Remote and Base unit.

3.3 To Move Several Motors:

- Set the UP/DOWN toggle switches for each motor to the desired direction. Each associated LED should light Green for UP, or Red for DOWN.
- Hold the press the GO button until the motors has moved the desired distance.
- Until remote unit is not used turn it off via STOP button – unit will also sleep for 3 minutes of inactivity – signaled by blinking of GREEN LED on Remote and Base unit.

4. WMCseries remote controller

WMCseries controller allows controlling the MCseries device via wireless connection.

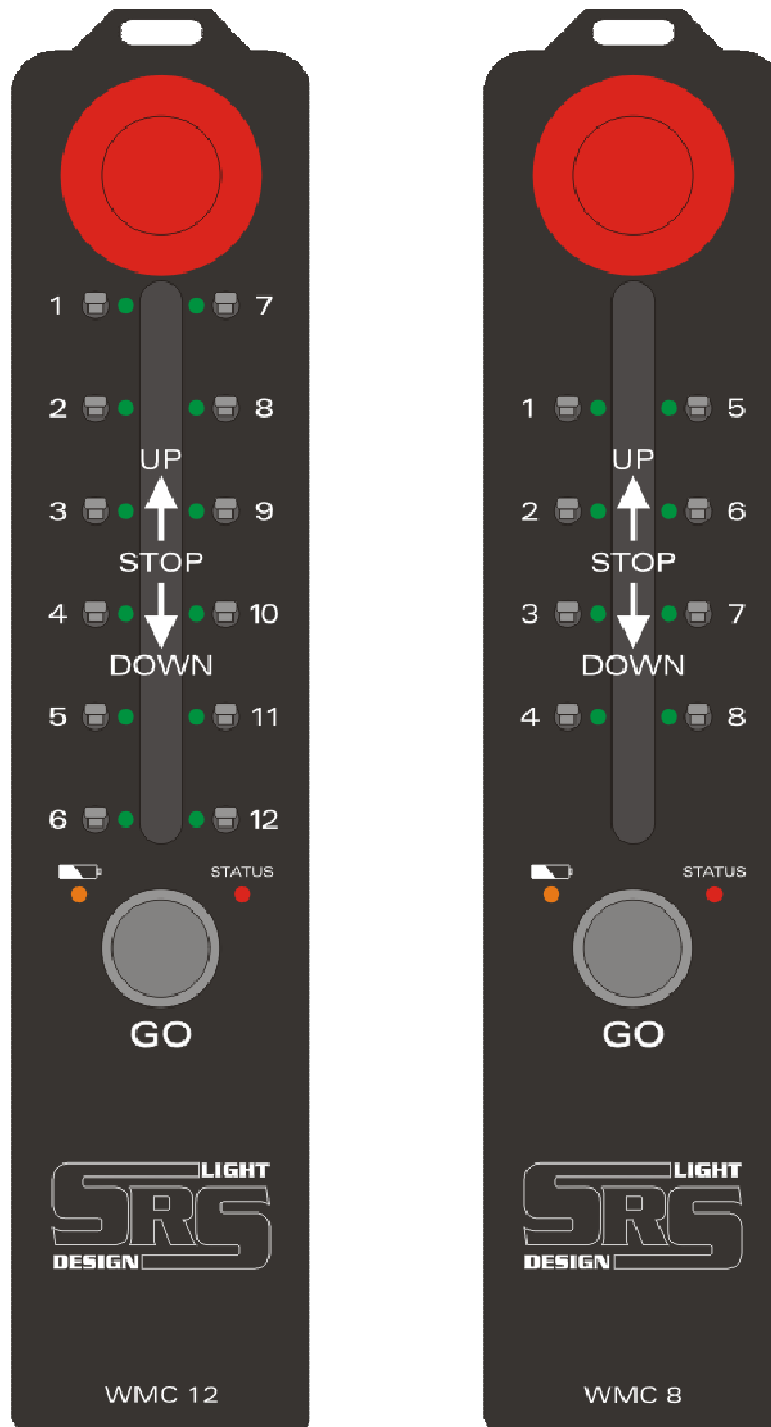

4.1 STOP:

This latching pushbutton switch turns the Hoist Control system off. Once the STOP button has been pressed, it locks into the off position and must be rotated clockwise and released before disengaging.

4.2 GO:

This pushbutton switch turns the selected channels of Hoist Control system ON when is active. Once the GO button has been pressed, the energizing of the hoists is on. The backlight of GO button in local mode on Base unit is on only while one or more direction switches in active position /up or down/.

4.3 DIRECTION SWITCHES:

They allow changing the direction of movement fore each motor/hoist separately:

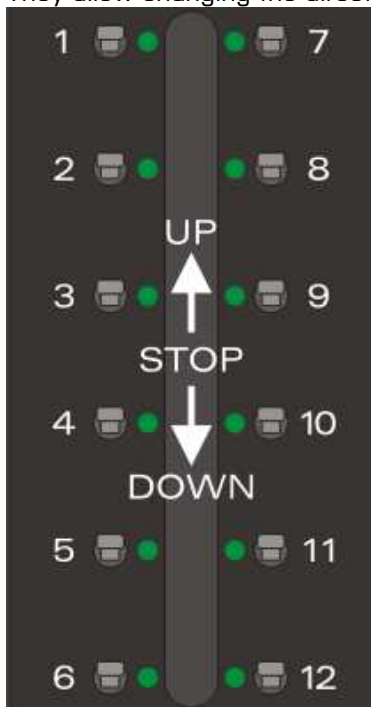

4.4 BATTERY STATUS LED:



Battery status LED indicator.

- Green :100-90%
- Orange :90-10%
- Red :10%
- Red + beep :5%

4.5 REMOTE STATUS LED:

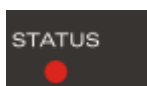

Status LED indicator of WMC remote unit.

- Green : Power on
- Green blinking : Power on – SLEEP - move the direction switch or press GO button to resume from sleep. This status becomes after 3 minutes of inactivity.
- Orange : Indicates that the direction switch activity
- Red : GO button is pressed – sending the commands to the Base unit

5. WMCseries base unit

5.1 WMCseries front panel

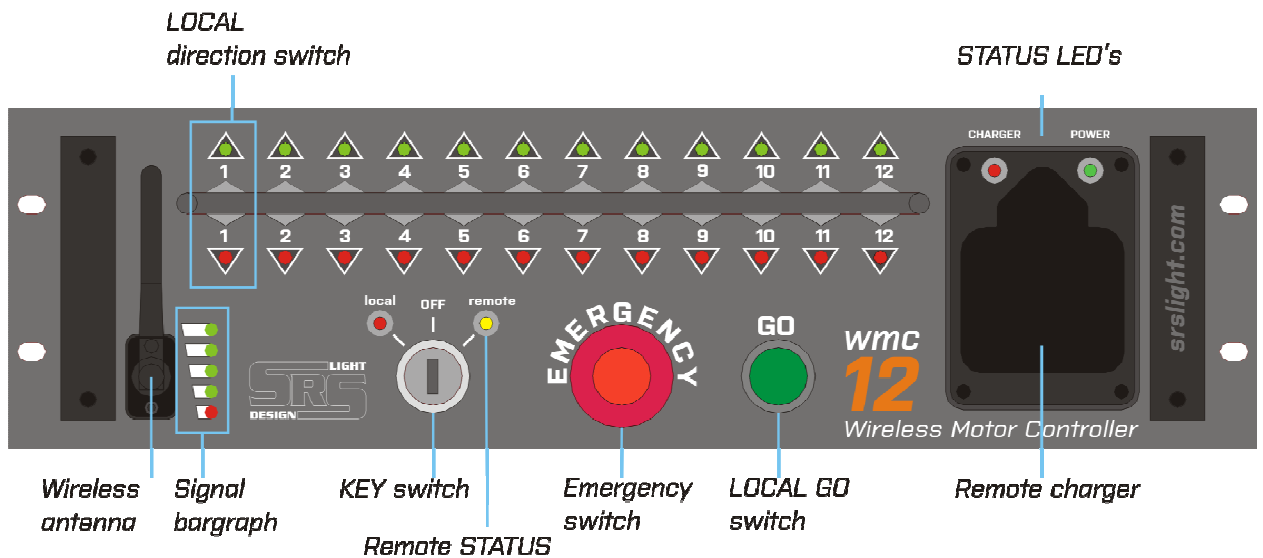

5.2 Charger status LED:

Status LED of charger located on WMC front panel is

- Green : Battery is fully charged
- Green blinking : Battery is charged for 90% or greater capacity
- Orange blinking : Not in rapid mode – waiting to be charged
- Red : Battery is in rapid charge mode
- Red blinking : Battery is unchargeable or not making proper contact
- No LED : Battery is not inserted

5.3 WMCseries back panel



6. Outputs wiring

6.1 Remote connector

Amphenol DS3106A28-21P

Pin	Function	CMC12A	CMC8A
1	M1 down	X	X
2	M1 up	V	V
3	M2 down	c	c
4	M2 up	d	d
5	M3 down	b	b
6	M3 up	h	h
7	M4 down	i	i
8	M4 up	k	k
9	M5 down	e	e
10	M5 up	Z	Z
11	M6 down	W	W
12	M6 up	L	L
13	M7 down	K	K
14	M7 up	U	U
15	M8 down	m	m
16	M8 up	f	f
17	M9 down	R	-
18	M9 up	P	-
19	M10 down	N	-
20	M10 up	M	-
21	M11 down	F	-
22	M11 up	E	-
23	M12 down	T	-
24	M12 up	S	-
25	Contactor ON	a	a
26	AC1 24V	g	g
27	AC1 24V	n	n
28	AC1 24V	p	p
29	AC2 24V	r	r
30	GROUND	s	s



6.2 Power connector

Neutrik NAC3MPA



6.3 REMOTE2/E-stop connector

Neutrik NC4FXX

- Pin 1. Safety line 1 in
- Pin 2. Safety line 1 out
- Pin 3. Safety line 2 in
- Pin 4. Safety line 2 out



Both safety lines are separate and normally closed /NC/ for arm state. Contacts will go to normally open /NO/ state for E-STOP activation!!!

7. Technical data

- Main Power: AC 230V, 50/60Hz, 1A

7.1 Protections and Safety:

- Dry contacts – all outputs are galvanic isolated
- Double - Recessed Emergency stop + SIL3 safety module
- Double encoded communication

7.2 Dimensions /W x D x H/:

WMC12: 483 x 365 x 132 mm

WMC8: 483 x 365 x 132 mm

8. Guarantee

MCseries hoist controller is sold with 2 years Manufacturer's guarantee. To have extended warranty conditions please contact manufacturer at sales@srslight.com.

Guarantee covers the original factory installed components of the controller and their correct functioning.

Warranty void if any part or replacement components is installed or modified without authorization from the manufacturer and/or the internal circuit is tampered or modified and/or the controller is operated outside normal use conditions – electrical power supply is not conform or there is connection error or mechanical damage of controller, including overload, improper use – BUT we as manufacturer always help you to repair your unit.

9. Declaration of conformity

DECLARATION OF CONFORMITY

According to guide lines 89/336 EEC and 92/31 EEC, 90/337 CEE Annex II A:

Name of producer: SRS Light Design s.r.o.

Address of producer: Rybnicna 36/D, SK- 83106 Bratislava, Slovak Republic
www.srslight.com/ sales@srslight.com, +421244681417

Declares that the product

Name of product: WMCseries Hoist controller: WMC8, WMC12 and variants

Types:

WMC-8 : Wireless controller 8 channels
WMC-12 : Wireless controller 12 channels

Corresponds with following harmonized standards:

Safety: EN60065, resp. EN 60950

EMC: EN55103-1, resp. EN55103-2

And

Is in compliance with following requirements:

Machinery directive: 98/37 CEE

Low Voltage directive: EEC 73/23

Bratislava, 10th of may 2010

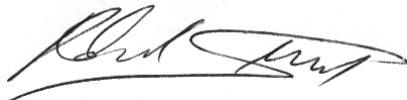

Robert Sloboda

10. Contents

1.	Safety information	1-2
2.	Functions and Control	2-3
3.	Operation	3-3
3.1	How to start	3-3
3.2	To Move a Single Motor:.....	3-3
3.3	To Move Several Motors:	3-3
4.	WMCseries remote controller.....	4-4
4.1	STOP:.....	4-4
4.2	GO:.....	4-5
4.3	DIRECTION SWITCHES:.....	4-5
4.4	BATTERY STATUS LED:.....	4-5
4.5	REMOTE STATUS LED:.....	4-5
5.	WMCseries base unit.....	5-6
5.1	WMCseries front panel	5-6
5.2	WMCseries back panel	5-6
6.	Outputs wiring	6-7
6.1	Remote connector.....	6-7
6.2	Power connector	6-7
6.3	REMOTE2/E-stop connector	6-7
7.	Technical data	7-8
7.1	Protections and Safety:	7-8
7.2	Dimensions /W x D x H/:	7-8
8.	Guarantee.....	8-9
9.	Declaration of conformity.....	9-10
10.	Contents	10-11

Bratislava, 4th of May 2011

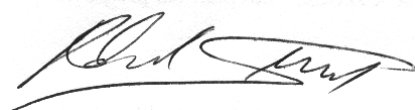

Robert Sloboda